

VEHICLEAC

PARKING AND TURN OFF, CHOOSE **VEHICLEAC**

12V / 24V DC AIR CONDITIONER

Global leading brand for DC truck air conditioning system



ShangHai VehicleAC Industry Co., Ltd

New air conditioner, new experience,
New energy parking air conditioner
with hard core attack



Content

- 
- 1. Product Specifications**
 - 2. Schematic Diagram of A/C System**
 - 3. Technical Parameter**
 - 4. Core Components**
 - 5. Duration of Working**
 - 6. Fuel Economy**
 - 7. Installation Process**
 - 8. Installation Successful Case**
 - 9. Certificate Authentication**

1. V-Cool 26 Specifications

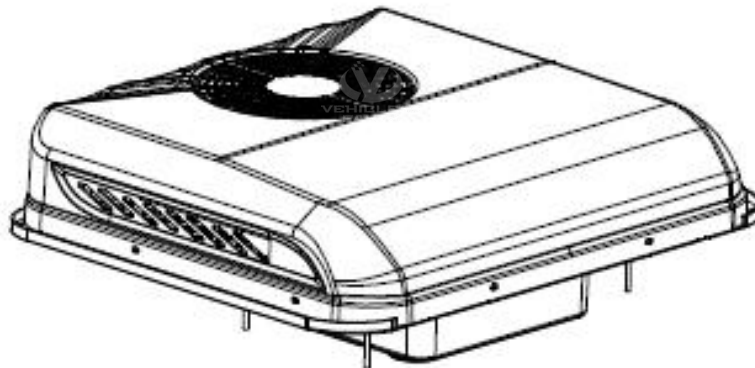
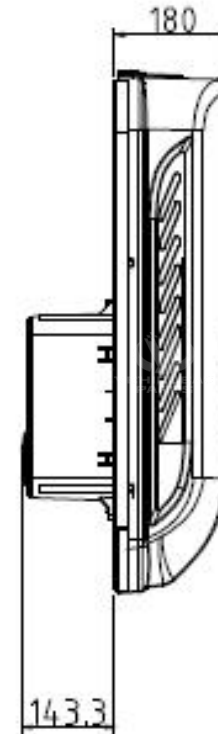
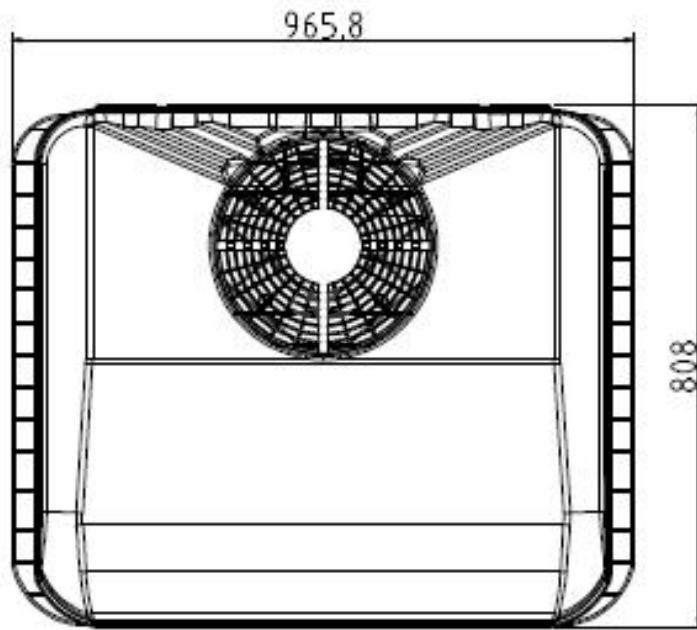

V-Cool 26

1.1 V-Cool 26 Specifications(Installation size)

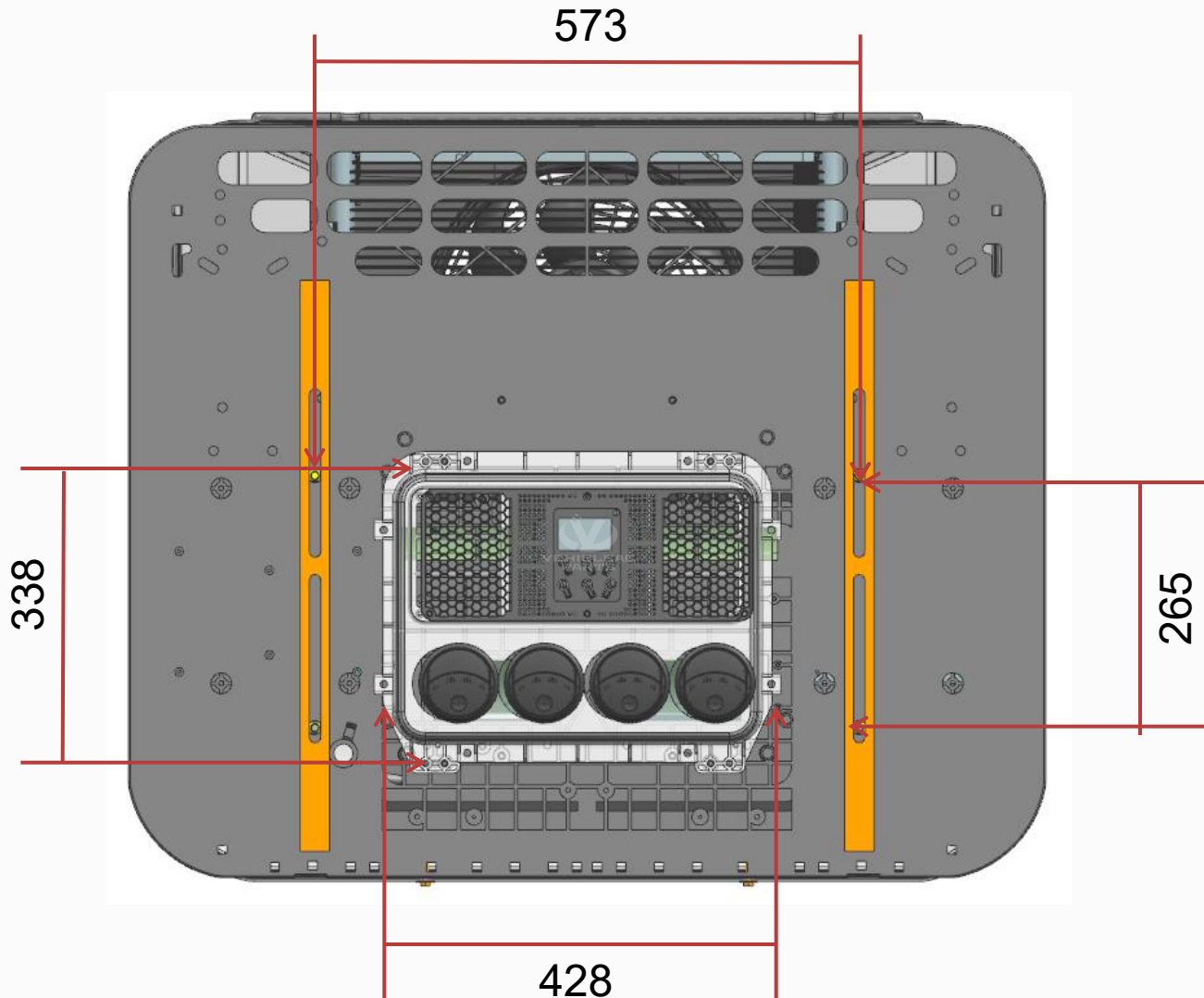

1.2 V-Cool 26 Specifications(Package dimensions)

Carton Box Size: 980*894*397

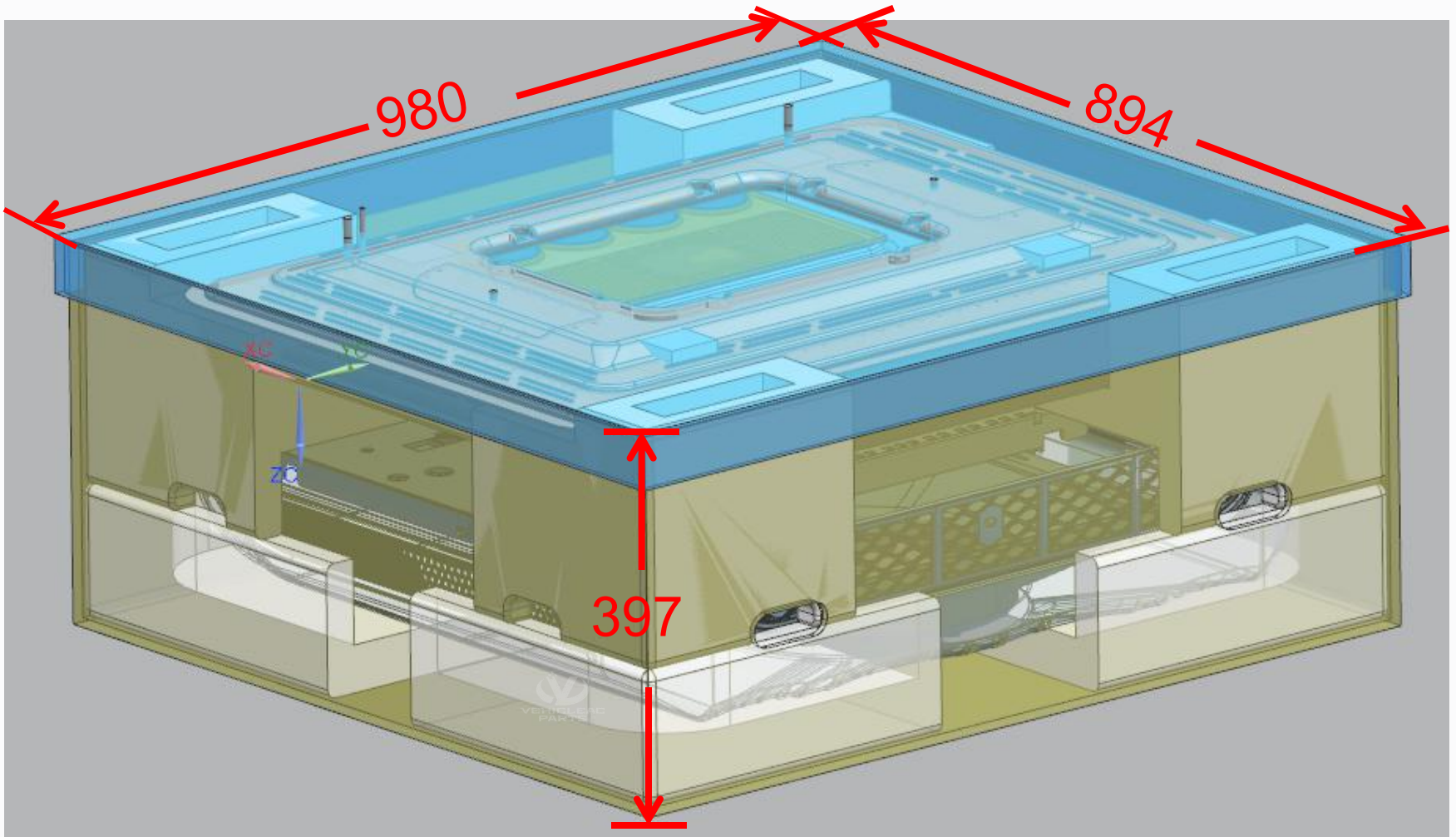

2. Schematic Diagram of V-Cool 26 A/C System

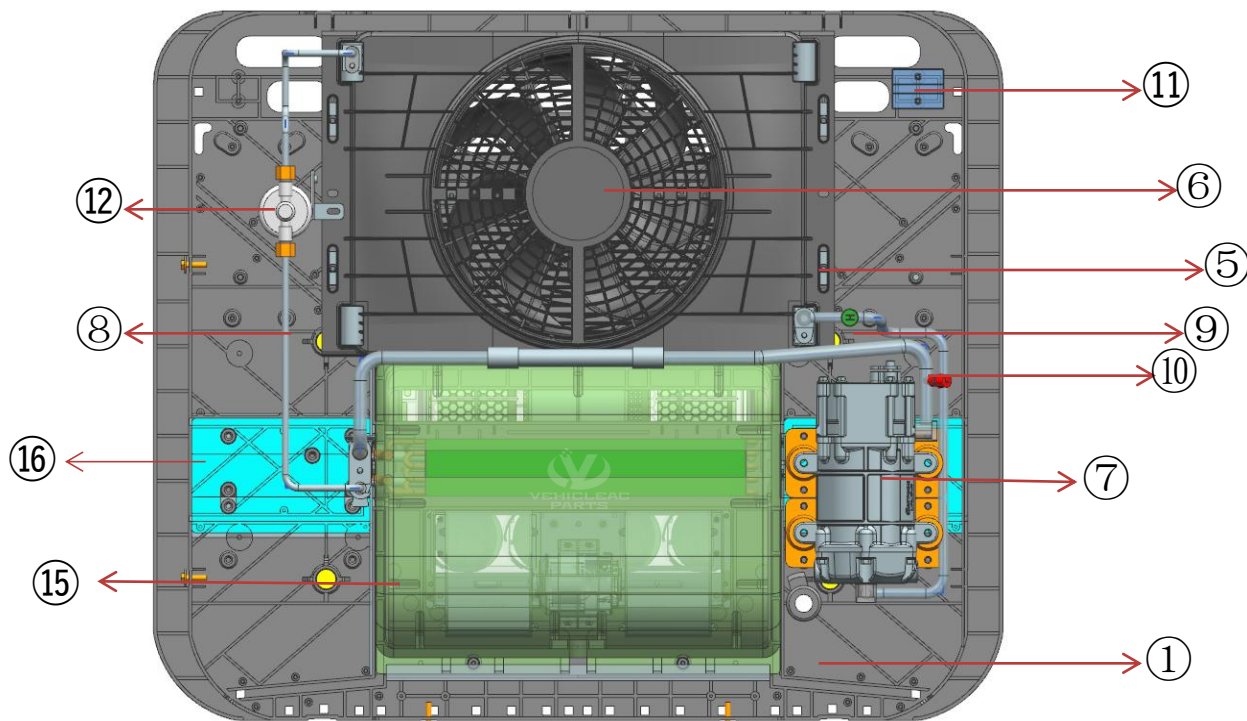

Exploded View of the Whole Air Conditioner

Number	Product Name	Number	Product Name
1	Install the Bottom Plate	8	Liquid Pipe Assembly
2	Blower (see inside the foam)	9	Low-pressure Pipeline Assembly
3	Evaporator core (see inside the foam)	10	High-pressure Pipeline Assembly
4	Expansion valve (see the figure below for details)	11	Power Cord Wiring
5	Condenser	12	Receiver Drier
6	Condenser Fan	13	A/C Wiring Harness (see the figure below for details)
7	Electric Compressor	14	Power Wire Harness (see the figure below for details)
15	Evaporator Foam (flame retardant)	16	Floor flap

3. Technical Parameter (24V)



Parameter Description	
Model	V-Cool 26
Rated cooling capacity (W)	800-2200
Rated power (W)	450-1100
Rated current (A)	18.5-50
Circulating air volume (m ³ /h)	150-380
Energy efficiency ratio (W/W)	2.2
Specification size (mm)	965*808*180
Refrigerant charge (g)	600±20
Refrigerants	R134a
Rated voltage (V)	24
Compressor	Scroll
Colour	Ivory/ Red
Set temperature (°C)	16-30
Noise	30-65(Internal fan)

4. Core Components

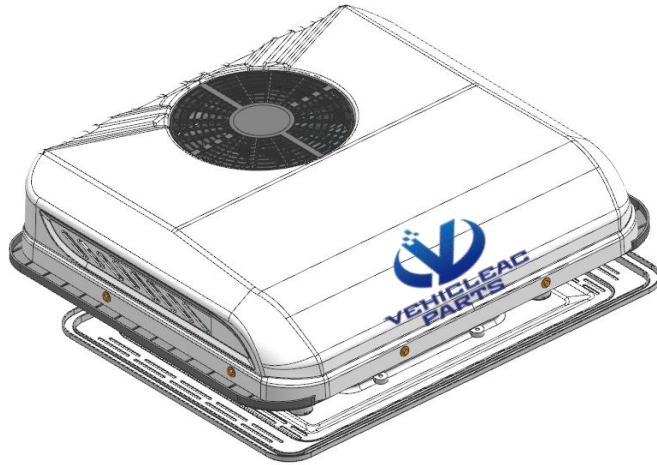

High energy efficiency ratio, High reliability, High safety, Low noise & vibration

The integrated compressor is specially developed for parking air conditioners by Dafu Heavy Industry. One-piece scroll compressor with matching grade for car factory, It has the characteristics of high energy efficiency ratio in a small space, low noise, fast cooling, good refrigerant heat dissipation, and stable performance.

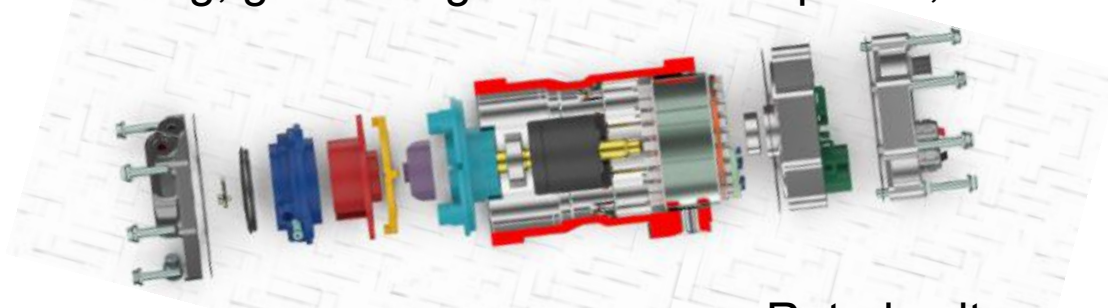

Rated voltage: DC24V

Displacement : 15/18cm³/r

Rotational Speed: 1000-4000rpm

4.1 Core Components



Micro-channel Heat Exchanger Parallel flow Coil, Double fins
Dimensions: 582*353*20,
54% larger heat dissipation area than similar condensers, smaller flow resistance, better heat dissipation and better performance.



10-inch electronic fan, 1600 air volume, 7 blades, low speed, low sound, long life
Rated voltage: DC24V
Power: 120W
Air volume: 1380m³/h.
Dual fan size: 784*342*113

4.2 Core Components



Air conditioning wire harness 10²*4m

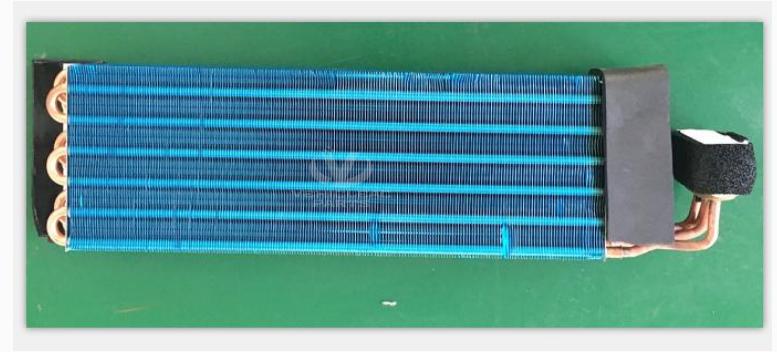

Evaporators adopt 30 pieces internally threaded copper tube, Dimensions: 475*76*126, Cooling capacity $\geq 2500W$, Better durability, surface hydrophilic treatment, higher heat exchange efficiency



Battery harness 10²*5m (insurance 80A)



Use a large turbo fan, with greater air volume, rated voltage: DC24V, Power: 80W, 4 windshields, up to 3600r/min

4.3 Core Components

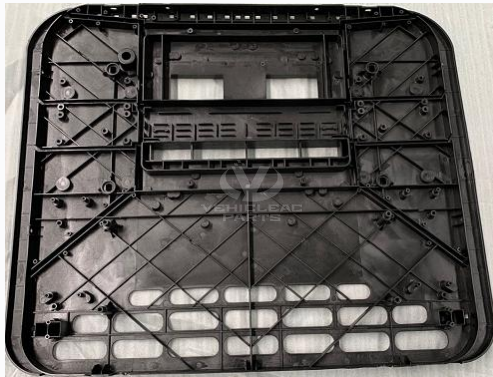

Special material for automotive engineering, PP+GF30, high strength, no deformation, anti-aging, more than 20 years of service life, enlarged chassis size, suitable for most vehicle models.



International CE certified environmental protection material EPS material, with high heat insulation, anti-flame retardant, recycled and reused many times, no pollution to the environment, foreign trade export quality and so on



The system can ensure the best refrigerant flow, lower pressure and more energy saving when the system is frequency conversion. In addition, a visual mirror is used to facilitate observation of the amount of refrigerant and facilitate later maintenance.



Vehicle-grade expansion valve, high control accuracy, sensitive response, rapid flow adjustment, energy saving and pressure reduction speed, sensitivity and reliability better than capillary structure

4.4 Core Components

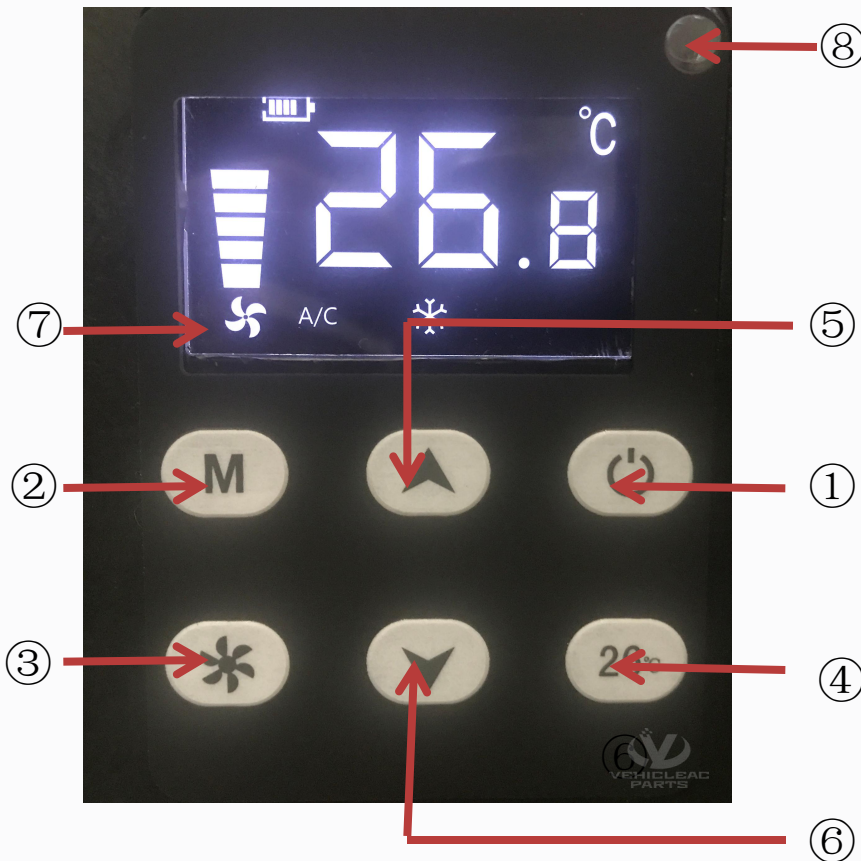

① Turn on / off key: Control the air conditioning turn on /off;

② Mode key:

Short Press: Work mode switching, cooling (automatic, energy-saving, powerful cool), heating, and ventilation modes can be cyclically switched.

Long press: Parameter setting and detection, long press the mode key for 10S when starting up, enter the parameter setting state, the parameters to be set in sequence are (current voltage, undervoltage, overpressure, air inlet temperature, air outlet temperature, fault number), in the setting state The number flashes displaying.

③ Wind speed key: short press to adjust the air volume, 5 gears cycle switching.

④ One key 26° C: Short press, one key to adjust the set temperature to 26° C.

Press and hold one key 26°C for 5s to enter the setting undervoltage state, and the undervoltage value will be displayed flashing. At this time, press the set temperature "+" and "-" keys to adjust the undervoltage value, the adjustment range (18~23), 10S no operation to exit the setting state.

⑤ Temperature "+": air conditioning set temperature increase;

⑥ Temperature "-": Air conditioning set temperature reduction;

⑦ Display window: display temperature, voltage, fault code, and display the collected environmental degree under normal conditions

⑧ Infrared reception: receive remote infrared signal.

5. Duration of Working

180A vehicle battery, the simulation of power consumption and usage time is as follows

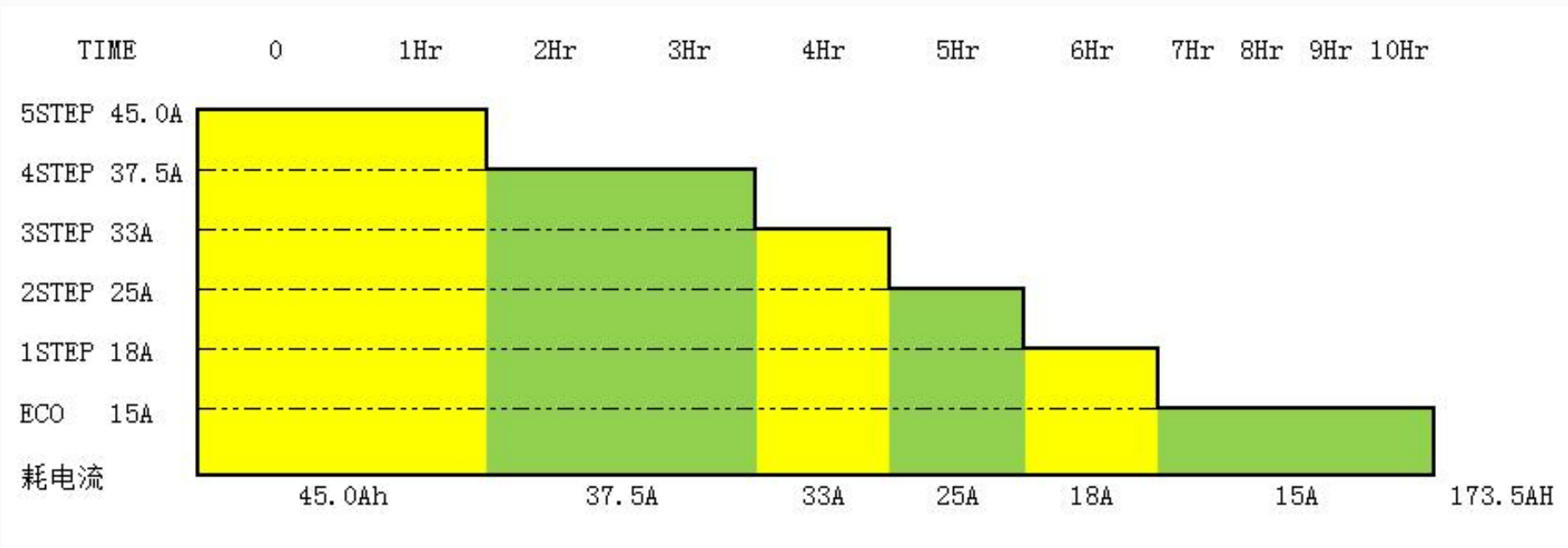

6. Fuel Economy

Use A/C time /Day A	Use days / year B	Fuel consumption / hour C	A/C use time / year $D=A*B$	A/C consumes fuel / year $E=C*D$	Fuel price / liter F	USE (2 Years) G	Total fuel savings $H=F*G$
4 Hour / Day	150 Day	2L/Hour	600 Hour	1200L	\$0.72 USD	2 Years	\$1715 USD

Combining the scenes of trucks' high-speed prohibition, normal rest of the driver, unloading and loading, etc., the comprehensive single-day idle time to use the air conditioner is obtained, so as to calculate the fuel economy of the product.

Do not consider the additional economic effects brought by uncontrollable expenses such as hotel accommodation and rest costs, vehicle mechanical parts idling and wear, and extended vehicle working hours.

7. Installation Process

Installation process of Rooftop parking air conditioner

1、 Remove the skylight, Clean the skylight surroundings
(If there is no skylight, the minimum opening size is 600*300)

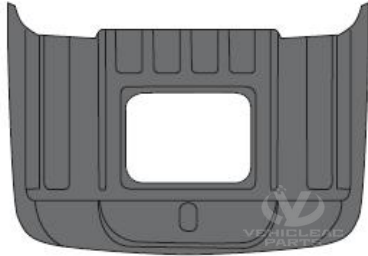

2、 Paste Skylight Sealing Sponge



3、 Install the air conditioner into the skylight

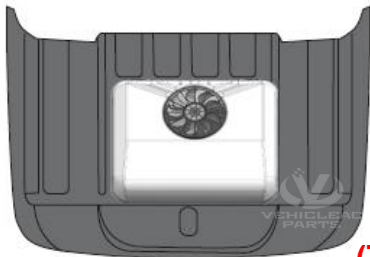

4、 Ready air conditioning units in place according to limiter position

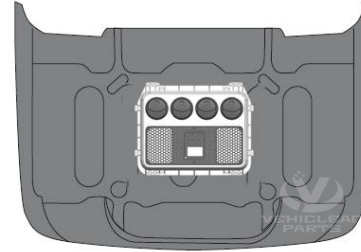

5、 Installation of pull - lined pressure plate (Torque :15NM)

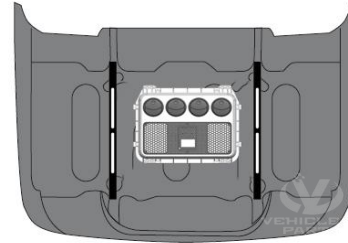

6、 Installation of decorative panels

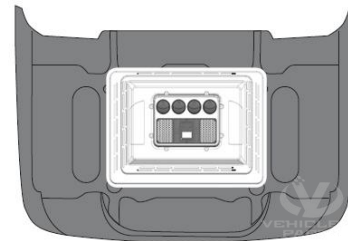

7、 Connect the main power cable and signal line connector, start commissioning

(The positive and negative poles of the main cable should be directly connected to the positive and negative poles of the vehicle battery)

8. Installation Successful Case



9. Certificate Authentication

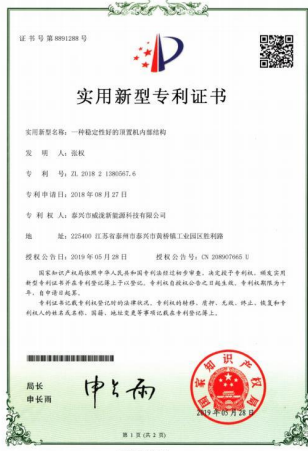
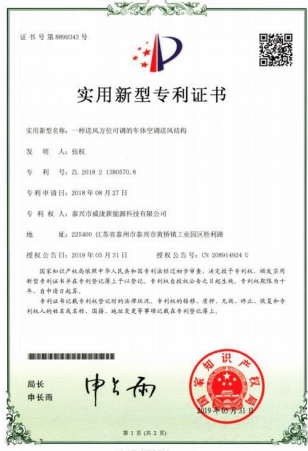
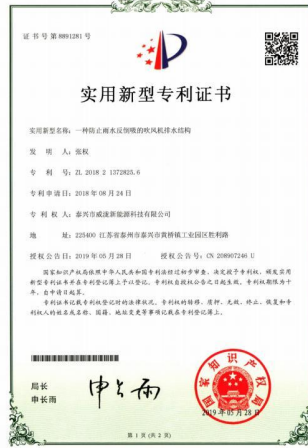
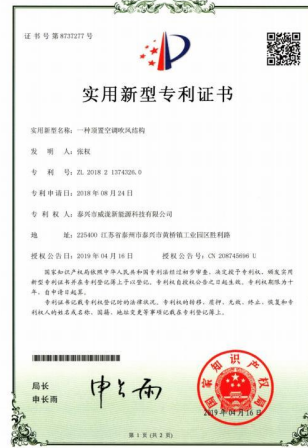
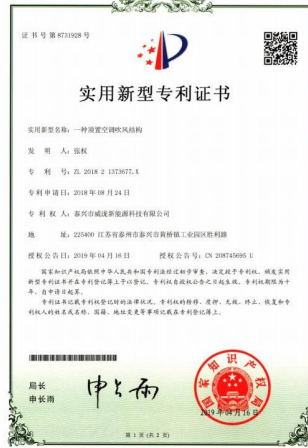
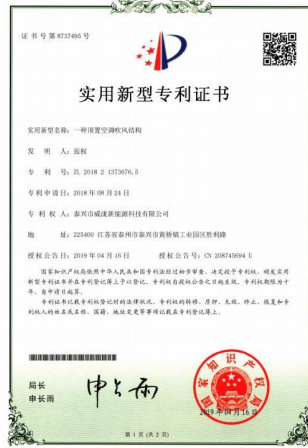

There are currently more than 30 authorized parking air-conditioning related patents





VEHICLEAC

PARKING AND TURN OFF, CHOOSE **VEHICLEAC**
12V / 24V DC AIR CONDITIONER

Global leading brand for DC truck air conditioning system

ShangHai VehicleAC Industry Co.,. LTD.

Tel: +86-021-58581023

Email: info@vehicleacparts.com

Website: www.vehicleacparts.com

FaceBook: <https://www.facebook.com/vehicleacparts/>

Address: No. 8-1098, Chuansha Road, Pudong New District, Shanghai, China

